



MITSUBISHI ELECTRIC AUTOMATION (THAILAND) CO., LTD.
 Bang-Chan Industrial Estate No. 111 Moo 4, Serithai Rd., T.Kannayao, A.Kannayao, BKK 10230 Thailand
 Tel: (66) 2517-1326, (66) 2919-9873 Fax: (66) 2517-1328 URL: www.meath-co.com E-mail: support@meath.co.th
บริษัท มิตซูบิชิ อิเล็กทริก ออโตเมชัน (ประเทศไทย) จำกัด
 นิคมอุตสาหกรรมบางชัน เลขที่ 111 หมู่ 4 ถนนเสรีไทย แขวงคันนายาว เขตคันนายาว กทม. 10230
 โทรศัพท์: (66) 2517-1326, (66) 2919-9873 โทรสาร: (66) 2517-1328 URL: www.meath-co.com E-mail: support@meath.co.th

MOTOR SPECIFICATION SHEET

MODEL : SF-PRO 0.75kW 2P
 USED FOR : 200V CLASS
 MANUFACTURER : MITSUBISHI ELECTRIC AUTOMATION (THAILAND) CO.,LTD.

| DESCRIPTION | DETAIL | | |
|----------------------------------|---|------------------------------------|--|
| PHASE | 3 | | |
| MODEL NAME | SF-PRO | | |
| RATED OUTPUT | 0.75 kW | | |
| POLE | 2 | | |
| CODE | MEATH CODE : 1M002F-200075LJDHO | | |
| OUTLINE DRAWING NO. | ONM84O263-* | | |
| RATED VOLTAGE (V) | 200 | 200 | |
| RATED FREQUENCY (Hz) | 50 | 60 | |
| RATED CURRENT (A) | 3.2 | 3.1 | |
| RATED SPEED (min ⁻¹) | 2855 | 3430 | |
| RATED EFFICIENCY | 82.8% | 82.9% | |
| EFFICIENCY CLASS | IE3 | | |
| THERMAL CLASS | 120 (E) | | |
| RATING | S1 (CONTINUOUS) | | |
| ENCLOSURE CONSTRUCTION | TOTALLY ENCLOSED FAN COOLED | | |
| DEGREES OF PROTECTION | IP44 (OUTDOOR WATERPROOF) | | |
| METHOD OF COOLING | IC411 | | |
| FRAME NO. | 80M | | |
| WEIGHT (kg) | 12 | | |
| STANDARD | IEC 60034-1, IEC 60034-30-1 | | |
| INSTALLATION | FOOT MOUNTED | | |
| ROTATION | CCW (VIEWED FROM SHAFT END) | | |
| BEARING | LOAD SIDE : 6204ZZ | OPPOSITE SIDE : 6204ZZ | |
| BEARING GREASE | UREA GREASE | | |
| NOISE (dB.A)* | 50Hz : 56 / 60Hz : 61 | | |
| VIBRATION | V15 | | |
| CIRCUMSTANCE | AMBIENT TEMPERATURE : -30 ~ +40°C | | |
| CONDITION | AMBIENT HUMIDITY : 100% RH (NO CONDENSATION) | | |
| | ABOVE SEA LEVEL : 1000m OR BELOW | | |
| | ENVIRONMENT : NO CORROSIVE/EXPLOSIVE GAS, NO STEAM OR CONDENSATION, MINIMAL DUST. | | |
| COLOR | MUNSELL N7 (GRAY) | | |
| TERMINAL BOX | NO. OF LEAD WIRES : 3 | SOURCE CONNECTION : TERMINAL BLOCK | |
| SHAFT SWING | ≤0.03mm | | |
| MATERIAL | FRAME : STEEL PLATE | BRACKET : ALUMINIUM | |
| | SHAFT : CARBON STEEL | STATOR CORE : ELECTRICAL STEEL | |
| | WIRE : ENAMELLED COPPER MAGNET WIRE | ROTOR CORE : ELECTRICAL STEEL | |
| | CONDUCTOR : ALUMINIUM | TERMINAL BOX : STEEL PLATE | |
| | PAINTING : POLYURETHANE RESIN | | |
| PRODUCTION COUNTRY | THAILAND | | |

*Value indicates representative value, not guaranteed value.

Specifications subject to change without notice.

| | | | | |
|--------------------------------|--|--|--|--|
| SPECIFICATION SHEET NO. | | | | |
| SS-M-8715-A | | | | |

MODEL SF-PRO THREE PHASE INDUCTION MOTOR OUTLINE DRAWING

INDOOR MOTOR

TOTALLY ENCLOSED FAN COOLED TYPE

DEGREES OF PROTECTION IP44

CUSTOMER _____
 USER _____
 FOR _____
 CUSTOMER'S ORDER NO. _____
 QUANTITY _____
 MFG. ORDER NO. _____

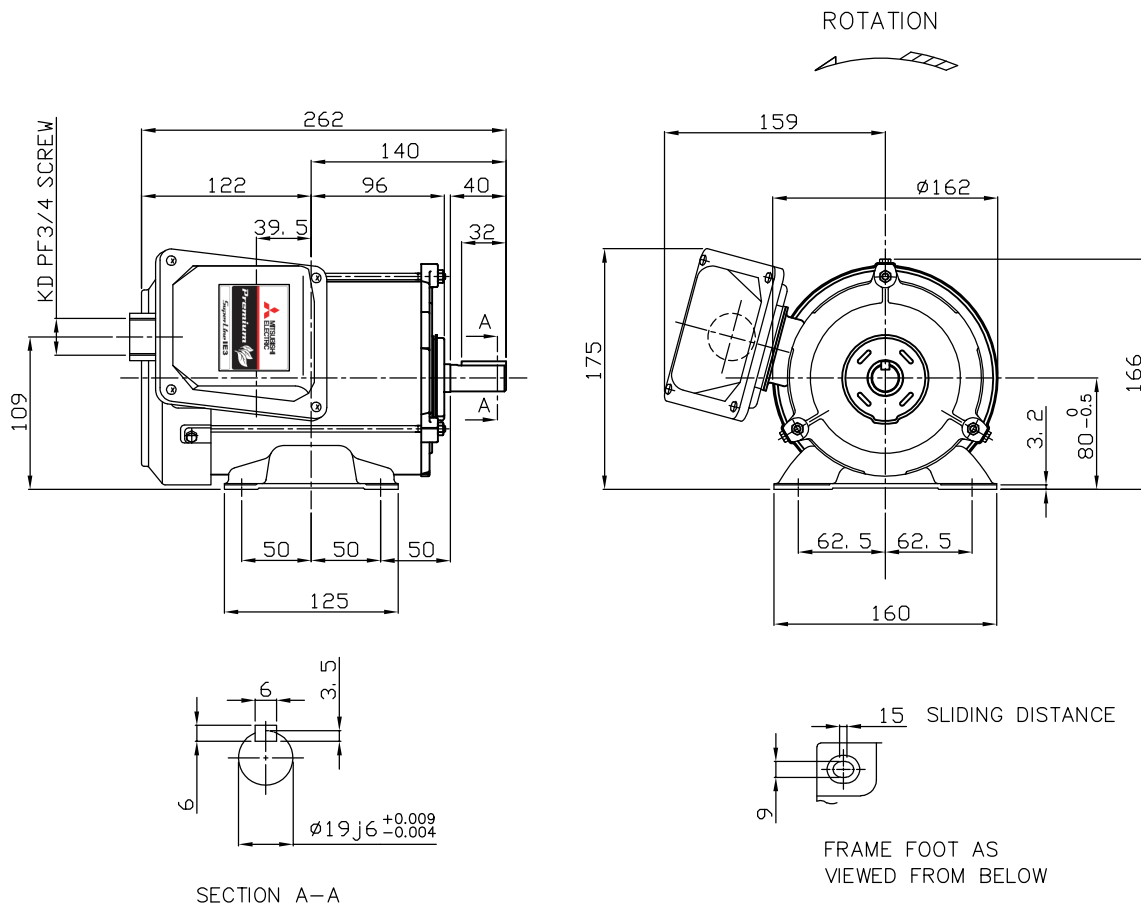

| YOUR ORDER | FRAME SIZE | RATING | TH. CLASS | AMB. TEMP. | BEARINGS | | COLOR | DIRECTION OF ROTATION (VIEWED FROM SHAFT END) | NO. OF TERMINALS | REMARKS |
|------------|------------|------------|-----------|------------|-----------|-----------|-------------------|---|------------------|---------|
| | | | | | LOAD SIDE | OPP. SIDE | | | | |
| | 80M | S1 (CONT.) | 120(E) | 40°C | 6204ZZ | 6204ZZ | GRAY (MUNSELL N7) | CCW | 3 | |

| YOUR ORDER | OUTPUT | | RATE VOLTAGE | IE CODE-RATED EFF. | | | | | | MASS(Kg) |
|------------|--------|------|--------------------------------|--------------------|-----------|-----------|-----------|-----------|-----------|----------|
| | kW | POLE | | 50Hz | | | | 60Hz | | |
| | | | | 200V | 380V | 400V | 415V | 200V | 400V | |
| | 0.75 | 2 | 200V 50Hz 200V 60Hz | IE3-82.8% | - | - | - | IE3-82.9% | - | 12 |
| | 0.75 | 2 | 380/400/415V 50Hz 400V 60Hz | - | IE3-82.0% | IE3-82.8% | IE3-83.0% | - | IE3-82.9% | 12 |
| | 0.75 | 4 | 200V 50Hz 200V 60Hz | IE3-83.8% | - | - | - | IE3-86.0% | - | 13 |
| | 0.75 | 4 | 380/400/415V 50Hz 400V 60Hz | - | IE3-83.5% | IE3-83.8% | IE3-83.5% | - | IE3-86.0% | 13 |

MITSUBISHI ELECTRIC AUTOMATION(THAILAND)CO.,LTD

| | | | |
|------------------|--|---------------------|------|
| | | OUTLINE DRAWING NO. | REV. |
| DIMENSION IN mm. | | 0 N M 8 4 0 2 6 3 | * |
| SCALE : NTS | | | |